

JCK Operation Manual

Binks



Binks

Read and follow all instructions and SAFETY PRECAUTIONS before using this equipment.

MODELS

JCK — Air Cap — Fluid Tip and Type of Feed (G: Gravity, S: Suction, P: Pressure)
 (Ex.): JCK-LV2-13P ← (JCK - LV2 Air Cap - Fluid Tip I.D. 1.3mm, Pressure Feed)

SPECIFICATIONS

Maximum Working Air Pressure: 0.69 MPa Maximum Working Fluid Pressure: 0.69 MPa
 Fluid Inlet : G1/4 Air Inlet: G1/4

Chart. 1

Type of Feed	Air Cap Name Part No.	Fluid Tip I.D. (mm)	Air Inlet Pressure (MPa)	Air Consumption (l/min)	Fluid Output (ml /min)	Fan Pattern Size (mm)	Gun Weight (g)	
Gravity	SS1 JCK-3-SS1	0.8	0.1	80	★50	★120	290	
		1.3			160	170		
		1.5			200	180		
	SS3 JCK-3-SS3	1.8	0.24	145	250	190		
		1.0			★100	★220		
		1.3			135	240		
	ST1 JCK-3-ST1	1.5	0.2	240	165			240
		1.8			200			
		1.3			120	130		
Suction	SS3 JCK-3-SS3	1.5	0.24	145	160	150		
		1.8			185	180		
		1.3			95	180		
	ST1 JCK-3-ST1	1.5	0.2	240	115	190		
		1.8			140	210		
		1.0			100	160		
	Pressure	CN1 JCK-3-CN1	0.8/1.0/ 1.3/1.5	0.24	220	200	210	
			300			260		
			100			150		
LV1 JCK-3-LV1		0.8/1.0/1.3	0.2	230	200	200		
					300	250		
					100	200		
LV2 JCK-3-LV2		0.8/1.0/1.3	0.2	230	200	270		
					300	320		

PARTS LIST

Chart. 2

Ref No.	Part No.	Description	Qty
1	JCK-6	RETAINING RING ASSY	1
2	See Chart.1	AIR CAP	1
3	JCK-440-XX	FLUID TIP & NEEDLE SET	1
4	JCK-7	BAFFLE ASSY	1
5	JUP-8-K5	BAFFLE GASKET	1
6	JCK-35	FLUID INLET SET	1
7	No parts sold	GUN BODY	1
8	JCK-44	PATTERN VALVE ASSY	1
9	JCK-443	AIR SEALS & AIR VALVE SET	1
10	JCK-12	AIR VALVE BUSHING ASSY	1

Ref No.	Part No.	Description	Qty
11	JCK-14-K5	NEEDLE SPRING	1
12	JCK-13	NEEDLE ADJUST SCREW	1
13	JCK-463	NEEDLE PACKING ASSY	1
14	JCK-108	TRIGGER SET	1
15	JCK-42	CHEATER VALVE ASSY	1
16	JCK-30	AIR CONNECTER	1

Note) Ref No.5 and No.11 are sold in packs of 5 pieces.
 Ref No.2: ex. JCK-3-ST1
 Ref No.3: ex. JCK-440-13 (Fluid Tip I.D. = 1.3mm)

Fig.1

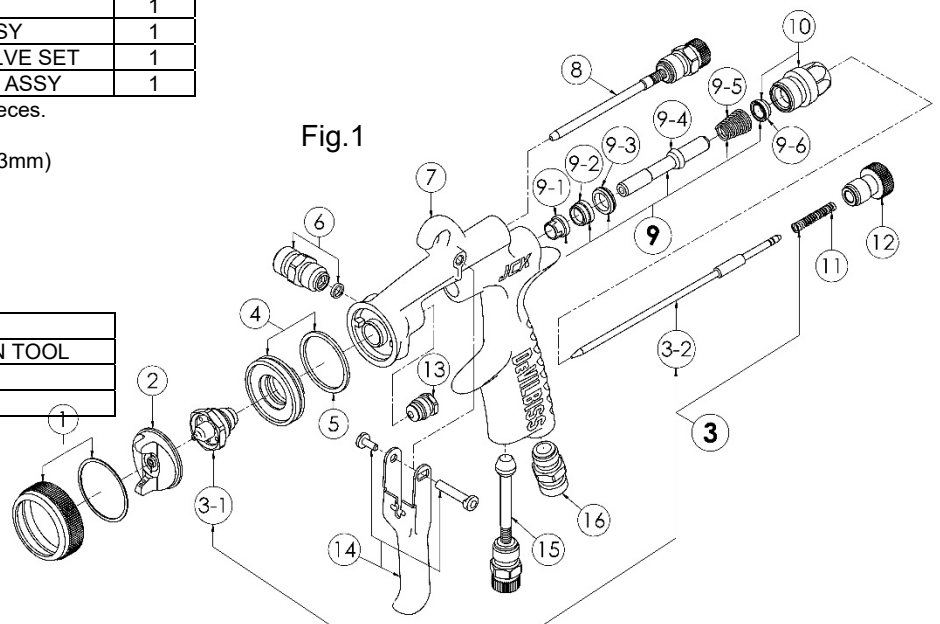



ACCESSORIES

Chart. 3 *Sold separately

Ref No.	Part No.	Description
17	LUNA2-34	AIR SEAL INSERTION TOOL
-	SSL-10	Gun Lube (60mL)
-	JCK-100	REPAIR KIT

In this part sheet, the words **WARNING**, **CAUTION** and **NOTE** are used to emphasize important safety information as follows:



















 WARNING
Hazards or unsafe practices which could result in severe personal injury, death or substantial property damage.

 CAUTION
Hazards or unsafe practices which could result in minor personal injury, product or property damage.

NOTE
Important installation, operation or maintenance information.

 **WARNING**

Read the following warnings before using this equipment.

	SOLVENTS AND COATING MATERIALS. Can be highly flammable or combustible when sprayed. Always refer to the coating material supplier's instructions and safety sheets before using this equipment.		INSPECT THE EQUIPMENT DAILY. Inspect the equipment for worn or broken parts on a daily basis. Do not operate the equipment if you are uncertain about its condition.
	READ THE MANUAL. Before operating finishing equipment, read and understand all safety, operation and maintenance information provided in the operation manual. Users must comply with all local and national codes of practice and insurance company requirements governing ventilation, fire precautions, operation, and housekeeping of working areas.		EQUIPMENT MISUSE HAZARD. Equipment misuse can cause the equipment to rupture, malfunction or start unexpectedly and result in serious injury.
	FIRE AND EXPLOSION HAZARD. Never use 1,1,1-Trichloroethane, Methylene Chloride, other Halogenated Hydrocarbon solvents or fluids containing such solvents in equipment with aluminum wetted parts. Such use could result in a serious chemical reaction, with the possibility of explosion. Consult your fluid suppliers to ensure that the fluids being used are compatible with aluminum parts.		GLOVES. Must be worn when spraying or cleaning the equipment.
	STATIC CHARGE. Fluid may develop a static charge that must be dissipated through proper grounding of the equipment, objects to be sprayed and all other electrically conductive objects in the dispensing area. Improper grounding or sparks can cause a hazardous condition and result in fire, explosion or electric shock and other serious injury.		WEAR SAFETY GLASSES. Failure to wear safety glasses with side shields could result in serious eye injury or blindness.
	TOXIC VAPOURS. When sprayed, certain materials may be poisonous, create irritation, or are otherwise harmful to health. Always read all labels, safety sheets and follow any recommendations for the material before spraying. If in doubt, contact your material supplier.		WEAR RESPIRATOR. The use of respiratory protective equipment is recommended at all times. The type of equipment must be compatible with the material being sprayed.
	LOCK OUT / TAG-OUT. Failure to de-energize, disconnect, lock out and tag-out all power sources before performing equipment maintenance could cause serious injury or death.		NEVER MODIFY THE EQUIPMENT. Do not modify the equipment unless the manufacturer provides written approval.
	NOISE LEVELS. The A-weighted sound level of pumping and spray equipment may exceed 85 dB(A) depending on equipment settings. Actual noise levels are available on request. It is recommended that ear protection is worn at all times while equipment is in use.		PROJECTILE HAZARD. You may be injured by venting liquids or gases that are released under pressure or flying debris.
	HIGH PRESSURE CONSIDERATION. High pressure can cause serious injury. Relieve all pressure before servicing. Spray from the gun, hose leaks or ruptured components can inject fluid into your body and cause extremely serious injury.		PRESSURE RELIEF PROCEDURE. Always follow the pressure relief procedure in the equipment instruction manual.
			KNOW WHERE AND HOW TO SHUT OFF THE EQUIPMENT IN CASE OF AN EMERGENCY.
			OPERATOR TRAINING. All personnel must be trained before operating finishing equipment.

IT IS THE RESPONSIBILITY OF THE EMPLOYER TO PROVIDE THIS INFORMATION TO THE OPERATOR OF THE EQUIPMENT.

PREVENTIVE MAINTENANCE

1. Daily lubrication and cleaning are necessary to maintain the best condition of the gun.
2. To clean the gun body, wipe exterior with solvent or cleaning solution dampened cloth. Do not immerse the gun in a solvent or cleaning solution as it may damage the gun or cause painting problems.
3. After using the gun, remove the paint and then pass an appropriate solvent or cleaning solution through the paint path to wash away any remaining paint.
4. Do not leave any solvent or cleaning solution in the paint path or paint cup. It may cause corrosion or damage.
5. The AIR CAP (2) can be immersed in solvent and brushed down for cleaning. If orifices are clogged, use a toothpick to remove obstruction. Never use a steel wire or hard instrument. This will damage air cap and result in a distorted spray pattern.
6. The following portions should be lubricated regularly (☐ in Fig.2); Sliding points of TRIGGER SET(14), PATTERN VALVE ASSY (8), CHEATER VALVE ASSY (15), NEEDLE ADJUST SCREW (12), AIR VALVE (9-4), and NEEDLE (3-2).
 - ◆ For lubrication, SSL-10 Gun Lube* is recommended. (*Sold separately, contains NO silicones or petroleum distillates.)
 - ◆ Do not lubricate to any portion where not instructed.
7. When installing AIR CAP (2), make sure no foreign materials adhered on RETAINING RING ASSY (1) and thread of body and then oil one drop of Gun Lube SSL-10. (⇒ in Fig.2)
8. Apply non-silicone grease lightly on NEEDLE SPRING (11) and AIR VALVE SPRING (9-5). Do not apply too much grease as it may clog the air passage.

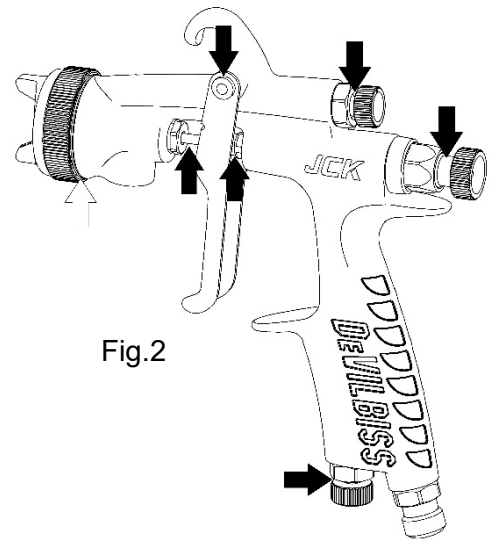

Fig.2

REPLACEMENT OF PARTS

Before replacing gun parts, remove materials from the gun for cleaning. Then release the air pressure of the gun and remove all hoses and paint containers. Perform the replacement work in a clean place and fix the gun properly. Use the appropriate tools indicated for replacement of parts. After replacing the parts, operate the gun and check that the replaced parts are functioning properly.

FLUID TIP & NEEDLE SET (3)

1. Loosen completely PATTERN VALVE ASSY (8) knob by turning the knob counterclockwise.
2. Remove NEEDLE ADJUST SCREW (12) and NEEDLE SPRING (11) and then withdraw NEEDLE (3-2).
3. Remove RETAINING RING ASSY (1) and AIR CAP (2).
4. Remove FLUID TIP (3-1) by using 19mm wrench.
5. Clean the seal surface on the GUN BODY side and tighten a new FLUID TIP with a torque wrench (recommended tightening torque: 8N-m).
6. Insert a new NEEDLE and NEEDLE SPRING and install the NEEDLE ADJUST SCREW.

FLUID INLET (6), AIR CONNECTOR (16)

FLUID INLET SET (6) and AIR CONNECTOR (16) are fixed together by sealing material. Do not remove these parts if you do not need them, as they may cause damage.

PATTERN VALVE ASSY (8), CHEATER VALVE ASSY (15)

Disassembling and reassembling PATTERN VALVE ASSY (8) and CHEATER VALVE ASSY (15) by using 13mm wrench. When disassembling and reassembling, turn the knobs completely counterclockwise.



AIR SEALS & AIR VALVE SET (9)

1. Remove NEEDLE ADJUST SCREW (12) and NEEDLE SPRING (11) and then withdraw NEEDLE (3-2).
2. Remove AIR VALVE BUSHING (10) by using 14mm wrench.
3. Withdraw VALVE SPRING (9-5), AIR VALVE (9-4).
4. Withdraw VALVE SEAT (9-3). Be careful not to damage the seal surface on the GUN BODY side.
5. Remove LOCK SCREW (9-2) by using 7mm hex wrench. Be careful not to damage the seal surface on the GUN BODY side.
6. Push the AIR SEAL (9-1) toward the back of the GUN BODY to remove it.
7. Remove the AIR SEAL (9-6) inside the AIR VALVE BUSHING. Be careful not to damage the seal surface on the AIR VALVE BUSHING side.
 - ◆ Do not reuse the removed AIR SEALS & AIR VALVE SET.
8. Install the new AIR SEALS & AIR VALVE SET in the reverse procedure of removal, being careful not to damage it.
 - ◆ The separately sold AIR SEAL INSERTION TOOL (17) is convenient for inserting the AIR SEALS (9-1, 3, 6).
9. Install the NEEDLE, NEEDLE SPRING and NEEDLE ADJUST SCREW.

NEEDLE PACKING ASSY (13)

1. Remove NEEDLE ADJUST SCREW (12) and NEEDLE SPRING (11) and then withdraw NEEDLE (3-2).
2. Remove NEEDLE PACKING ASSY (13) by using 10mm wrench.
3. Install a new NEEDLE PACKING ASSY. Use a 10mm wrench to tighten it until it stops lightly first, and then tighten it about 1/16 turn.
4. Install the NEEDLE, NEEDLE SPRING and NEEDLE ADJUST SCREW.

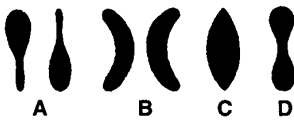
TROUBLE SHOOTING

Problem	Cause	Correction
Will not spray	No air or material is supplied to the gun. CHEATER VALVE ASSY (15) nob is not properly adjusted. NEEDLE ADJUSTING SCREW (12) is not properly adjusted.	Check air and material lines. Adjust accordingly. Adjust accordingly.
Improper spray pattern 	A, B: Material build-up on the AIR CAP (2) or FLUID TIP (3-1). A, B: AIR CAP (2) or FLUID TIP (3-1) damaged. C, D: Incorrect fluid delivery or viscosity. C, D: Incorrect air pressure.	Clean the AIR CAP or FLUID TIP. Replace. Adjust fluid delivery and viscosity. Adjust air pressure.
Intermittent or fluttering spray 	Insufficient material in the cup or loose Connector. Partially obstructed fluid passage or hose. Loose FLUID TIP (3-1). Material build-up on the seating on FLUID TIP (3-1) and GUN BODY (7). Damaged FLUID TIP (3-1).	Fill material or tighten the Connector. Clean or replace. Tighten. Clean. Replace.
Fluid leaking from NEEDLE PACKING ASSY (13)	Worn or damaged NEEDLE PACKING ASSY (13). Worn or damaged NEEDLE (3-2).	Replace. Replace.
Dripping from FLUID TIP (3-1)	Material build-up on the seating on FLUID TIP (3-1) and NEEDLE (3-2). Worn or damaged FLUID TIP (3-1) or NEEDLE (3-2). NEEDLE PACKING ASSY (13) and NEEDLE (3-2) are stuck together. Loose NEEDLE ADJUST SCREW (12).	Clean. Replace. Clean and lubricate. Adjust accordingly.

DeVilbiss Binks Japan KK

Head Office 1-15-5 Fukuura, Kanazawa-ku,
Yokohama, Kanagawa, 236-0004, Japan
TEL : 045-785-6434 FAX : 045-785-6517
www.binks.co.jp

OM_HG_JCK-E01_2025.05